



ARTICULO: 2222
Válvula de Aguja extremos roscados.
Threaded ends Needle valve.

Características

1. Válvula de Aguja.
2. Construcción en acero carbono ASTM A105
3. Extremos roscados según ASME B 2.1 NPT.
4. Estopada de eje en PTFE + Grafito.
5. Presión máxima de trabajo 3000 Lbs.
6. Rango Presión / Temperatura:
 1/4"-1/2" = 220 Bar / 260 °C.
 3/4"-1" = 220 Bar / 240 °C.

Features

1. Needle valve.
2. Made of Carbon steel ASTM A105.
3. Threaded ends according ASME B2.1 NPT
4. Stem Packing PTFE + Graphite.
5. Max. Working pressure 3000 Lbs.
6. Pressure / Temperature Range:
 1/4"-1/2" = 220 Bar / 260 °C.
 3/4"-1" = 220 Bar / 240 °C.

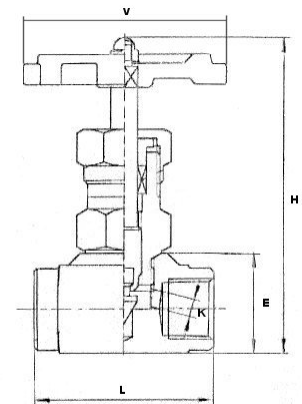
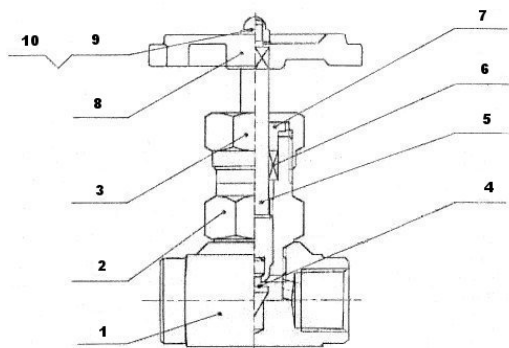

Nº	Denominación / Name	Material	Acabado Superficial/Surface Treatment
1	Cuerpo / Body	ASTM A-105	Cincado / Zinc golden
2	Bonete / Bonnet	ASTM A-105	Cincado / Zinc golden
3	Tuerca prensaestopas / Nut	ASTM A-105	Cincado / Zinc golden
4	Aguja / Needle	Inox. A182 F6 / S.S. A182 F6	-----
5	Eje / Stem	Inox. A182 F6 / S.S. A182 F6	-----
6	Estopada / Stem packing	Teflón + grafito / PTFE + graphite	-----
7	Prensaestopas / Packing nut	ASTM A-105	Cincado / Zinc golden
8	Volante / Handwheel	Aluminio / Alluminium	Pintado / Painted
9	Tuerca / Nut	Acero Carbono / Carbon Steel	Cincado / Zinc
10	Arandela / Washer	Acero Carbono / Carbon Steel	Cincado / Zinc





DIMENSIONES GENERALES / GENERAL DIMENSIONS

Ref	Medida/ Size	PN (Lbs)	Dimensiones/Dimensions (mm)					Peso/ Weight (Kg)
			E	H	L	K	V	
2222 02	1/4"	3000	25	85	50	3	63	0.260
2222 03	3/8"	3000	30	100	55	4	63	0.360
2222 04	1/2"	3000	34	115	60	6	72	0.530
2222 05	3/4"	3000	40	120	70	8	72	0.760
2222 06	1"	3000	45	138	75	9	80	1.175

DIAGRAMA DE PERDIDAS DE CARGA / HEAD LOSSES DIAGRAM

(H₂O – 20 °C Flujo Horizontal / Horizontal flow).

